

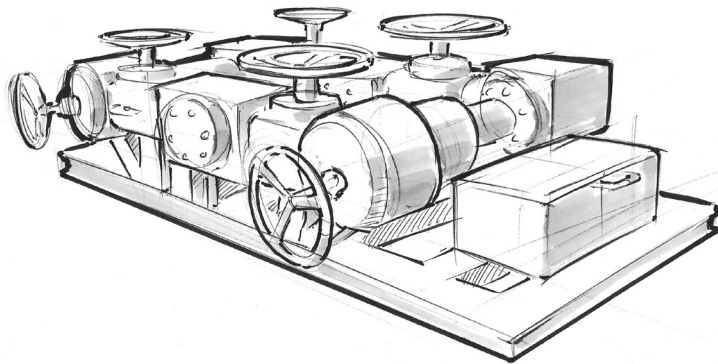

Well Testing Choke Manifold



Choke manifold's provide primary well control during well test operations. The dual choke design allows choke changes without shutting in the well; and the manifold's have the configuration capabilities to maintain critical flow and hydrate formation.

There are a variety of sizes, pressure and temperature ratings available to meet our client's demands. Every choke manifold provided by CETCO includes all necessary components for API 6A series compliance.

Technical Specifications

Equipment	10K 3-1/16"	15K 2-9/16"	15K 2-9/16" Dual Valve	20K 2-9/16"	15K Plug Valve
Choke Size	2"	2"	2"	1"	3/4"
Skid Dimensions (L x W x H)	10' x 8' x 4'	9' x 3'2" x 3'7"	12'6" x 8' x 2'10"	12'6" x 6' x 4'	6'5" x 4'3" x 3'5"
Weight (lbs.)	7,000	7,500	11,575	14,000	2,200
M.A.W.P (psi)	10,000	15,000	15,000	20,000	15,000
Maximum Temperature (°F)	250	250	250	250	250
Minimum Temperature (°F)	-20	-20	-20	-20	-20
Inlet - Outlet Connection	3-1/16" 10K	2-9/16" 15K	2-9/16" 15K	2-9/16" 20K	2" 15K
Deck Load Capacity (lbs./ft²)	87-1/2	263	116	187	N/A

